

# CONSTRUCTION SITE BMPS

Patrick Grogan, P.E. Q.S.D.

A series of several parallel white lines of varying lengths, slanted diagonally from the bottom left towards the top right, located on the right side of the slide.

## E.7.b.2. Construction Outreach and Education

### (a) Permittee Staff Training

(i) **Task Description** – Within the second year of the effective date of the permit, the Permittee shall ensure that all staff implementing the construction site storm water runoff control program are adequately trained.

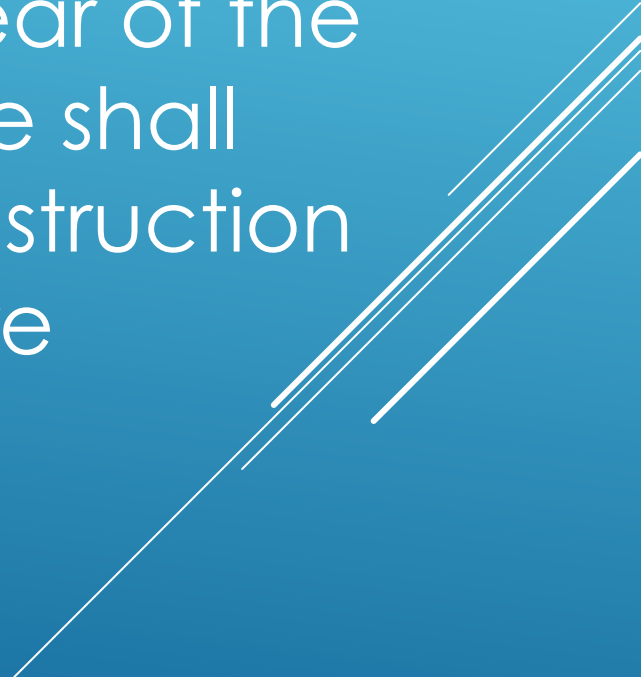

# REVIEW TOPICS

- ▶ CGP & Non-CGP
  - ▶ CGP Inspection Requirements
  - ▶ Construction BMPs
  - ▶ Enforcement
- 
- A decorative graphic consisting of several parallel white lines of varying lengths, slanted upwards from left to right, located in the bottom right corner of the slide.







Board



Programs



Drinking Water



Water Quality



Water Rights



Notices



Water Boards



Search



### SMARTS LOGIN

User ID:

Password:

[Login](#)

[Create Account](#)

[Unlock](#), [Reset Password](#) or [Forgot User ID](#)



Public User Menu



Permit FAQs



SMARTS Resources



Email SMARTS Help

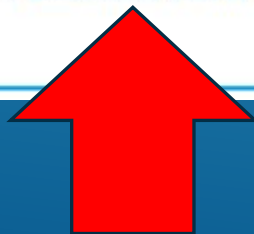



## Stormwater Multiple Application and Report Tracking System

# SMARTS

### Storm Water Data Public Access

[Back to Home Page](#)

**Note: Nightly maintenance on the stormwater public reports is scheduled 8 pm - 9 pm.  
Data may be inaccessible during this time.**

- [Search for Owners/Operators or Facilities/Sites](#)
- [Download NOI Data By Regional Board](#)
- [Storm Water Reports - Industrial](#)
- [Storm Water Reports - Construction](#)
- [Storm Water Reports - Municipal](#)
- [Storm Water Overview Reports](#)
- [Storm Water QSD Reports](#)
- [Storm Water QISP Reports](#)
- [Compliance Group Reports](#)

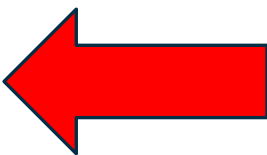

### Subscribe to our Email Lists

- [Subscribe to our Storm Water email lists](#)

### Storm Water Contacts

- General Inquiries:
  - ✉ [stormwater@waterboards.ca.gov](mailto:stormwater@waterboards.ca.gov)
  - ☎ Toll Free: 1-(866)-563-3107
- [State and Regional Board Contact Information](#)
- [Report a Storm Water Violation](#)
  - Report a Non-Filer - **Let us know if a business does not have a Storm Water Permit.**
  - Report a QSD/QSP (Construction General Permit Qualified SWPPP Developer/Qualified SWPPP Practitioner)



**Notice Of Intent Search Criteria**

Welcome to the Interactive Search for Storm Water Notice Of Intents!

**Search Criteria:**

Application:  

Application Type:

Processed Between:   and  

Owner/Operator Name:

Owner/Operator Street:

Developer Name:

SIC Code:

Status:

Application ID:

WDID:

Region:

County:

Facility/Site Name:

Facility/Site Street:

Facility/Site City:

Facility/Site Zip:

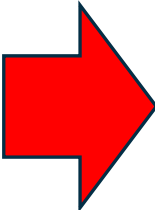



Notice Of Intents Search Results

Following are the results that matched with your search criteria. To refine or start a new search, click Back button on the browser.

[Export to Excel](#) [Back to Search](#)

App ID	WDID	Application Type	Status	Status Date	Owner/Operator Name & Address	Site/Facility Name & Address	NOI Form	Attachments	Receipt Letter
575668	3 27C404725	Construction	Active	08/15/2024	Seaside Peninsula Acquisition Group LLC 5600 Mariner Street Tampa California 33609	Bayonet Golf Course Maintenance Facility Monterey Road Seaside California 93955	<a href="#">NOI Form</a>	<a href="#">View Attachments</a>	<a href="#">Receipt Letter</a>
570641	3 27C403224	Construction	Active	03/04/2024	Seaside Peninsula Acquisition Group LLC 5600 Mariner Street Tampa California 33609	19681 McClure Way – Improvement Plan 19681 McClure Way Seaside California 93955	<a href="#">NOI Form</a>	<a href="#">View Attachments</a>	<a href="#">Receipt Letter</a>
569581	3 27C402913	Construction	Active	01/22/2024	Monterey Regional Water Pollution Control Agency 5 Harris Court Bldg D Monterey California 93940	Groundwater Replenishment Project Injection Well Facilities Ph 4 Eucalyptus Road and General Jim Moore Boulevard Seaside California 93955	<a href="#">NOI Form</a>	<a href="#">View Attachments</a>	<a href="#">Receipt Letter</a>
555870	3 27C399440	Construction	Active	12/28/2022	Seaside Peninsula Acquisition Group LLC 5600 Mariner Street Tampa California 33609	Grand Hyatt Seaside Resort 1 McClure Way Seaside California 93955	<a href="#">NOI Form</a>	<a href="#">View Attachments</a>	<a href="#">Receipt Letter</a>
555776	3 27C399143	Construction	Active	11/14/2022	Ascent Apartments QOZB LLC 3021 Citrus Circle Suite 130 Walnut Creek California 94598	Ascent Seaside Broadway Avenue and Terrace Street Seaside California 93955	<a href="#">NOI Form</a>	<a href="#">View Attachments</a>	<a href="#">Receipt Letter</a>
544848	3 27C395993	Construction	Active	12/21/2021	Chartwell School 2511 Numa Watson Road Seaside California 93955	Chartwell School Building Demolition 2511 Numa Watson Road Seaside California 93955	<a href="#">NOI Form</a>	<a href="#">View Attachments</a>	<a href="#">Receipt Letter</a>
539826	3 27C394743	Construction	Active	08/10/2021	California State University Monterey Bay 100 Campus Center Seaside California 93955	CSUMB Soccer Stadium 1086 Fourth Street Seaside California 93940	<a href="#">NOI Form</a>	<a href="#">View Attachments</a>	<a href="#">Receipt Letter</a>
539375	3 27C394675	Construction	Active	08/04/2021	California American Water 511 Forest Lodge Rd Pacific Grove California 93950	General Jim Moore Boulevard Shared Pipeline Project Along the North Bound Lane of General Jim Moore Boulevard Seaside California 93955	<a href="#">NOI Form</a>	<a href="#">View Attachments</a>	<a href="#">Receipt Letter</a>
538194	3 27C394627	Construction	Active	07/30/2021	Marina Coast Water District 11 Reservation Road Marina California 93933	Linear Underground Overhead Project ORD Village Forcemain Replacement Project East and West of Highway 1 Seaside California 93955	<a href="#">NOI Form</a>	<a href="#">View Attachments</a>	<a href="#">Receipt Letter</a>
528139	3 27C392004	Construction	Active	11/10/2020	Shea Homes LP 2630 Shea Center Dr Livermore California 94551	The Enclave Fairway Drive Seaside California 93955	<a href="#">NOI Form</a>	<a href="#">View Attachments</a>	<a href="#">Receipt Letter</a>
511954	3 27C387873	Construction	Active	08/23/2019	California American Water 511 Forest Lodge Rd Pacific Grove California 93950	MPWSP Transfer Pipeline Linear Construction Project Seaside California 93955	<a href="#">NOI Form</a>	<a href="#">View Attachments</a>	<a href="#">Receipt Letter</a>
481808	3 27C378613	Construction	Active	05/05/2020	Heitzinger Associates LTD 100 THE EMBARCADERO SAN FRANCISCO California 94105	Val Strough Honda 1 Heitzinger Plaza Seaside California 93955	<a href="#">NOI Form</a>	<a href="#">View Attachments</a>	<a href="#">Receipt Letter</a>
497184	3 27W003741	Construction	Expired	08/15/2018	Monterey Peninsula Unified School District 540 Canyon Del Rey Blvd Ste 3 Monterey California 93940	Seaside High School Track and Field Renovation 2200 Noche Buena Street Seaside California 93955	<a href="#">NOI Form</a>	<a href="#">View Attachments</a>	<a href="#">Receipt Letter</a>
449774	3 27W001989	Construction	Expired	11/15/2014	California State University Monterey Bay 100 Campus Center Seaside California 93955	CSUMB Storm Drain Improvements Intersection of 6th avenue and Inter Garrison Road Seaside California 93955	<a href="#">NOI Form</a>	<a href="#">View Attachments</a>	<a href="#">Receipt Letter</a>
448159	3 27W001916	Construction	Expired	11/26/2014	Bureau of Land Management 940 2nd Avenue Marina California 93933	Fort Ord National Monument Eucalyptus Road and Parker Flats Seaside California 93955	<a href="#">NOI Form</a>	<a href="#">View Attachments</a>	<a href="#">Receipt Letter</a>
436475	3 27W001194	Construction	Expired	08/09/2013	California State University Monterey Bay 100 Campus Center Seaside California 93955	CSU Monterey Bay 100 Campus Center Seaside California 93955	<a href="#">NOI Form</a>	<a href="#">View Attachments</a>	<a href="#">Receipt Letter</a>
509310		Construction	Returned	09/05/2019	Seaside Senior Living LLC 560 First St Lake Oswego Oregon 97034	Seaside Senior Living LLC 550 Monterey Road Seaside California 93955	<a href="#">NOI Form</a>	<a href="#">View Attachments</a>	<a href="#">Receipt Letter</a>
474177		Construction	Returned	07/27/2016	California State University Monterey Bay 100 Campus Center Seaside California 93955	8th Avenue and Inter Garrison Rd Roundabout 8th Avenue and Inter Garrison Rd Seaside California 93955	<a href="#">NOI Form</a>	<a href="#">View Attachments</a>	<a href="#">Receipt Letter</a>
455915		Construction	Returned	02/03/2021	California State University Monterey Bay 100 Campus Center Seaside California 93955	Promontory Pathway 2061 InterGarrison Road Seaside California 93955	<a href="#">NOI Form</a>	<a href="#">View Attachments</a>	<a href="#">Receipt Letter</a>
320521		Construction	Returned	02/08/2007	Seaside City PWD 440 Harcourt Ave Seaside California 93955	Seaside AUto Center Revitalization btw Fremont & Del Monte Seaside California 93955	<a href="#">NOI Form</a>	<a href="#">View Attachments</a>	<a href="#">Receipt Letter</a>



Risk Level	Visual Inspections					Sample Collection	
	Monthly Non-storm Water Discharge	Pre-storm Event		Daily Storm	Post Storm	Storm Water Discharge	Receiving Water
		Baseline	REAP				
1	X	X			X		
2	X	X	X	X	X	X	
3	X	X	X	X	X	X	X

- Risk Level on cover page of the project SWPPP
- Weekly Inspections for all Risk Levels
- REAP – Rain Event Action Plan
- Pre-storm triggered by 50% of precipitation per NOAA
- Post storm triggered by 1/2 inch of precipitation
- Sample collection – turbidity, pH, non-visible pollutants

- Grading (sediment discharge, tracking, dust)
  - Foundation (full washouts, pH runoff)
  - Framing (housekeeping)
  - Exterior coatings (full washouts, contaminated runoff)
- 



**STORMWATER POLLUTION PREVENTION PLAN**  
for

**Linear Underground/Overhead Project: Fremont,  
Broadway, and Ortiz Sewer Main Upgrades**

**RISK TYPE: Type 1 LUP**

WDID#

**Legally Responsible Person [LRP]:**

Seaside County Sanitation District  
440 Harcourt Avenue  
Seaside, CA 93955

**Prepared for:**

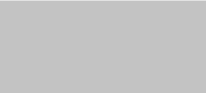

**Project Address:**

Ortiz Avenue, Holly Street, and the Transportation Agency  
of Monterey County (TAMC) right-of-way in City of Sand City; and Del Monte, Boulevard, Clementina Avenue, Alhambra  
Street, and Broadway Avenue  
Seaside, CA 93955

**SWPPP Prepared by:**

Incompl, Inc.



**SWPPP Preparation Date**

October 12, 2021

**Estimated Project Dates:**

Start of Construction                      Completion of Construction

09/17/2021

04/16/2022

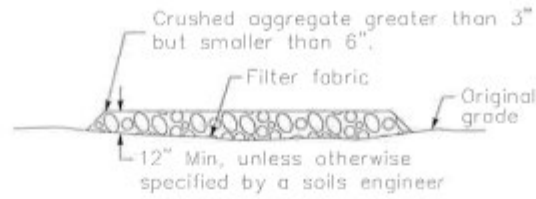

SECTION B-B  
NTS

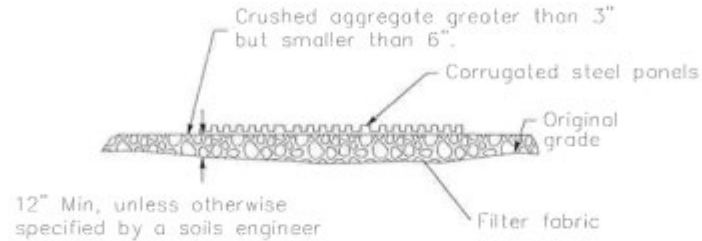

SECTION A-A  
NOT TO SCALE

NOTE:  
Construct sediment barrier and channelize runoff to sediment trapping device

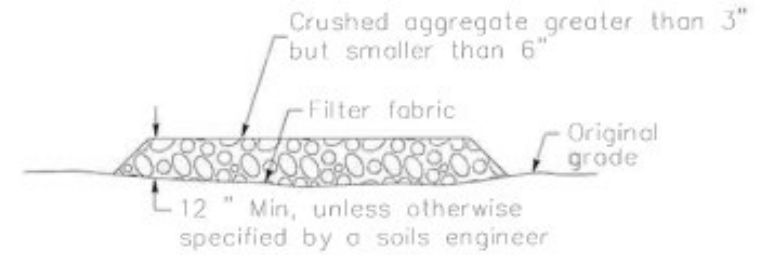
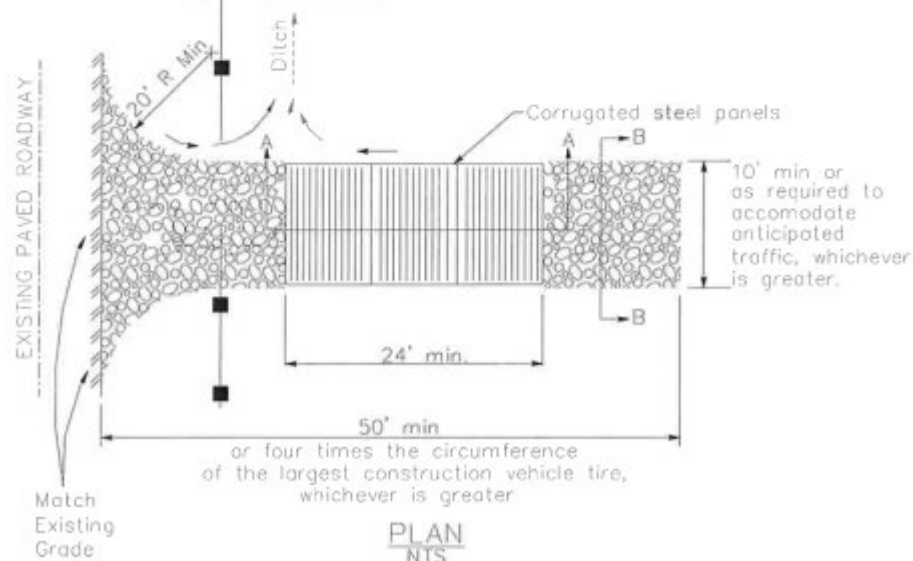
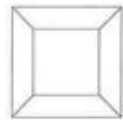

SECTION B-B  
NTS

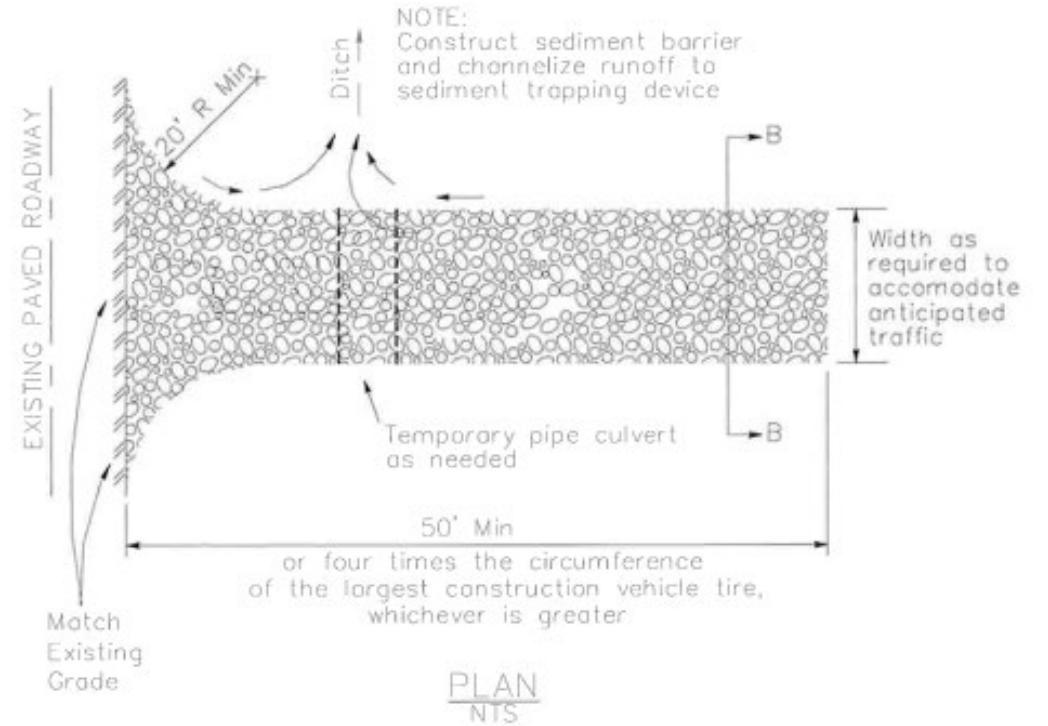









- Trenched in 2" min
- Staked or secured 4' max
- Ends overlapped
- Spaced along slope perpendicular to flow

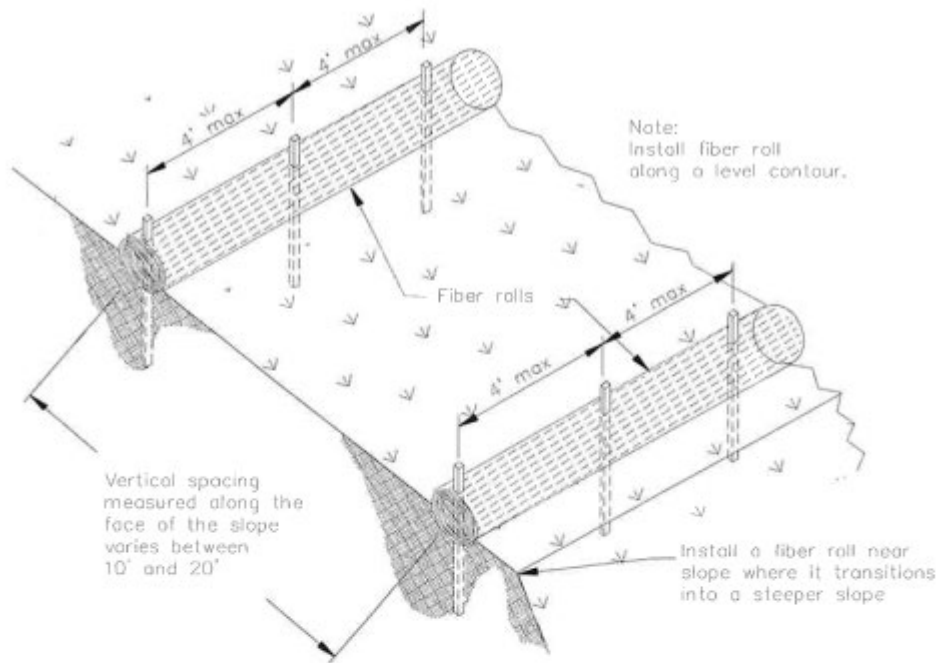

TYPICAL FIBER ROLL INSTALLATION

N.T.S.

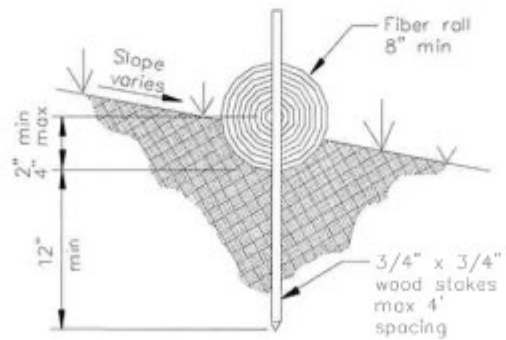

ENTRENCHMENT DETAIL

N.T.S.

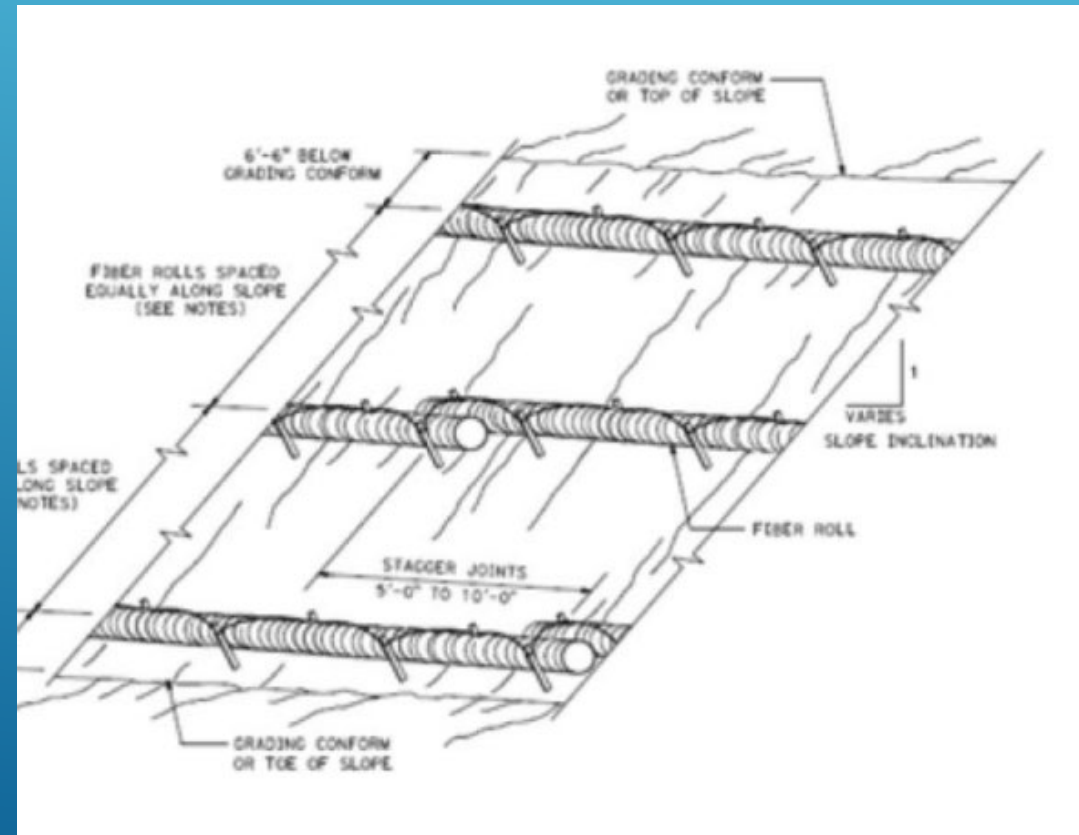



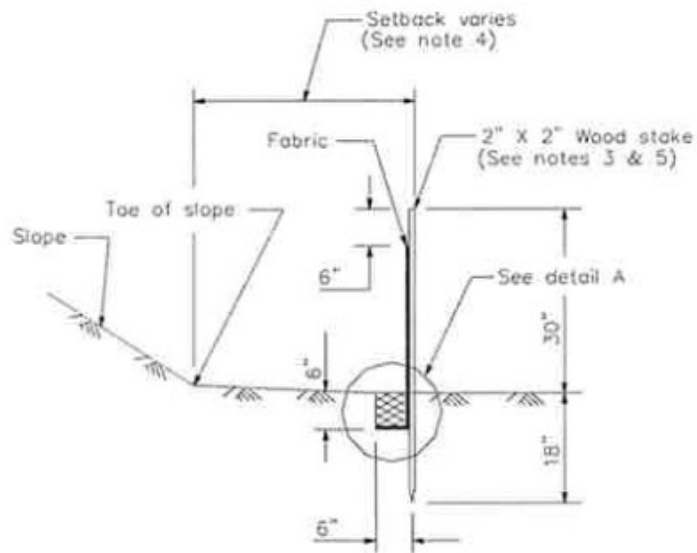

SECTION A-A

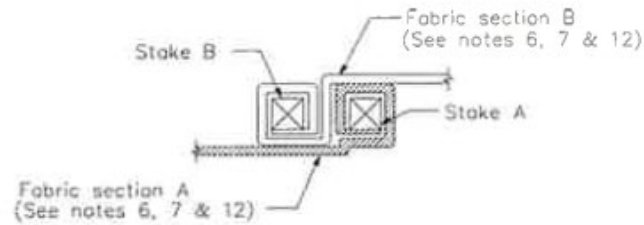

JOINING SECTION DETAIL (TOP VIEW)

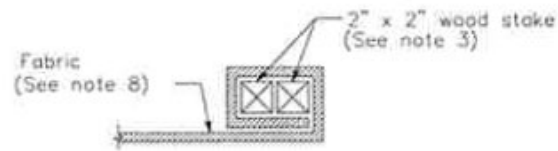

END STAKE DETAIL (TOP VIEW)

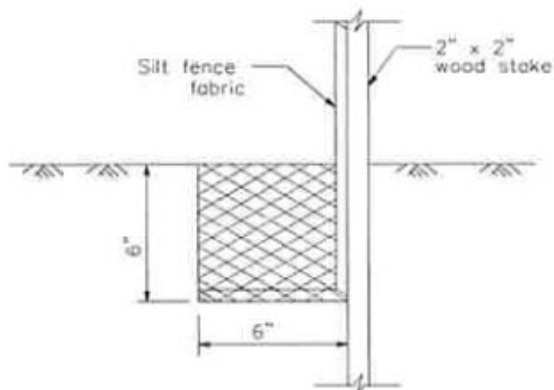

DETAIL A

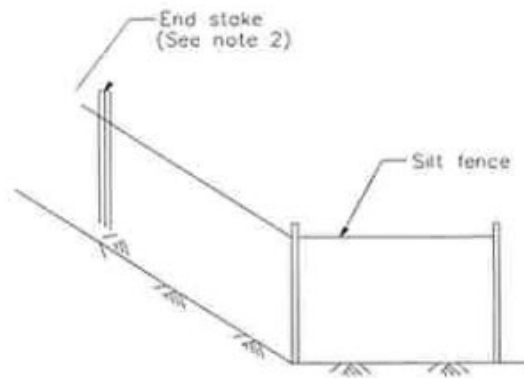

END DETAIL

- 6 inch x 6 inch trench
- Key in 12 inches of fabric
- Backfill with soil
- Setback 3 feet from toe of slope
- Remove sediment when 1/3 of barrier height reached
- Repair or replace damaged fencing





- Covered in advance of rain
- 50 feet from drainage areas
- Empty frequently
- Protect from wind







- Soil Stabilizers/binders
- Pesticides/herbicides
- Fertilizers
- Detergents
- Plaster
- Fuel, oil, grease
- Asphalt/concrete
- Hazmat



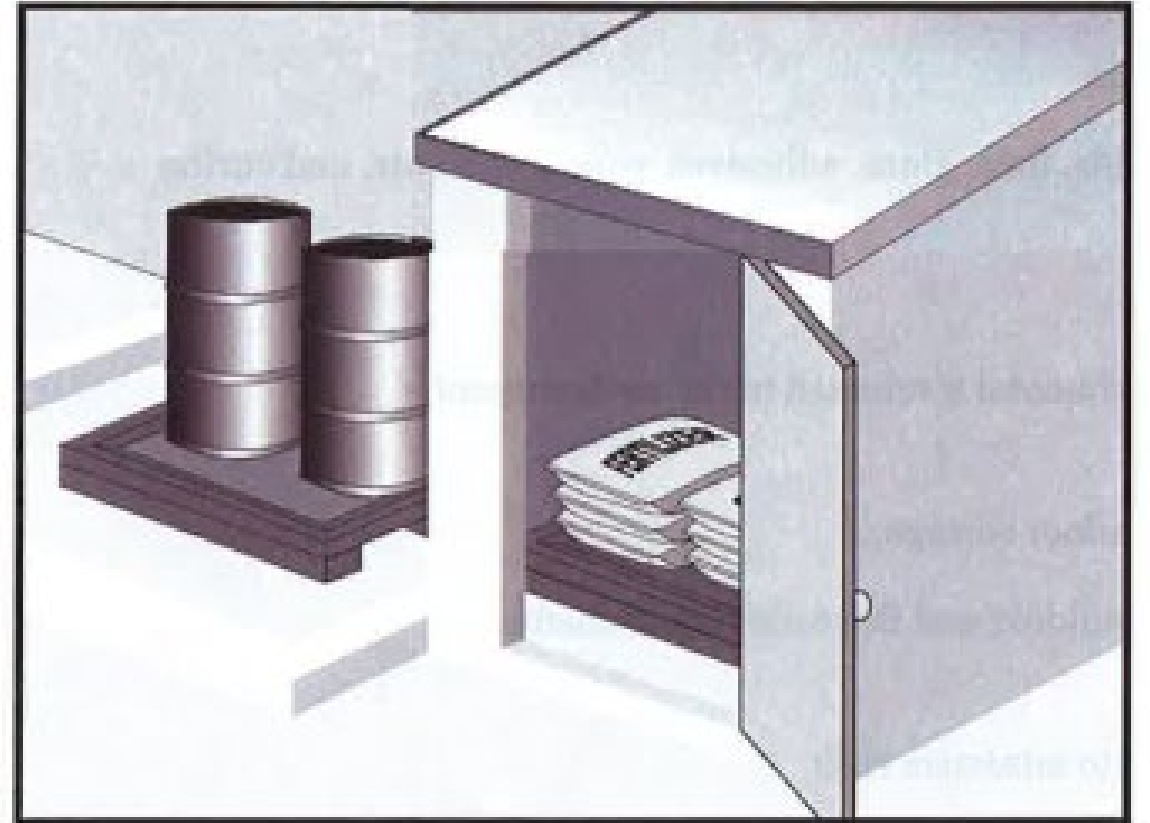
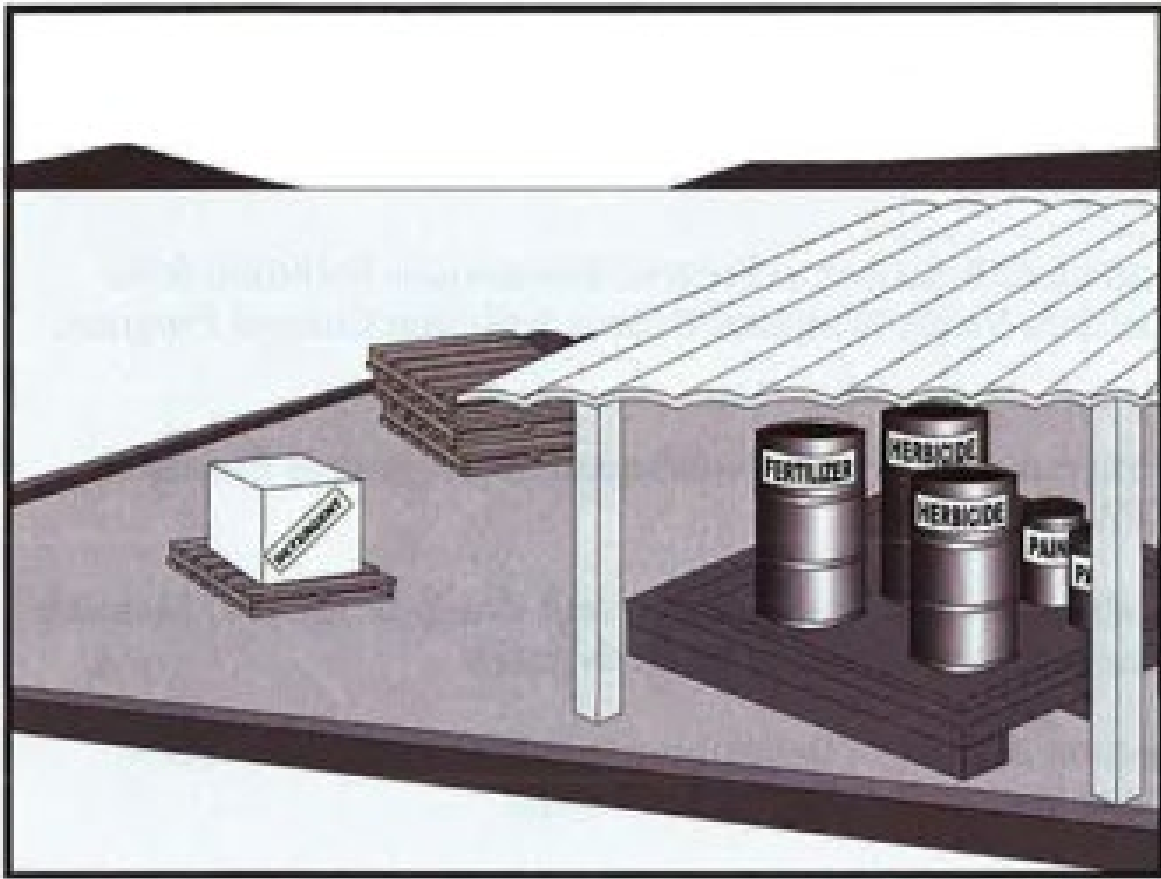







## Enforcement

- 72 hours to correct deficiencies is standard
- Elevate to Building Official/City Eng/PW Director
- Contact Regional Water Board (fines)

## Keep in mind

- Impossible to prevent all failures
  - Seeking continual improvement
- 
- A decorative graphic consisting of several parallel white lines of varying lengths and orientations, located in the bottom right corner of the slide.

**Thank You**

